

QuickSetter+™ Balancing Valve with flow meter

© Copyright 2018 Caleffi

132 Series



Function

The QuickSetter+™ static balancing valve contains a built-in flow meter and sight gauge, negating the need for differential pressure gauges and reference charts. Circuit balancing is fast, easy and accurate. Constructed of DZR low-lead brass, QuickSetter+™ is ideally suited for use in plumbing applications such as hot water recirculation systems. The built-in check valve protects against circuit thermo-siphoning. The outlet temperature gauge (optional) verifies the fluid temperature in the circuit. The flow meter sight gauge is dry (not exposed to the fluid) thus eliminating the possibility of gauge clouding/scaling over time. The QuickSetter+™ can also be used in heating systems.

Product range

132 Series Balancing valve with flow meter sizes 1/2", 3/4", and 1". Includes check valve and optional outlet temperature gauge.

Technical characteristics

Valve

Materials:	Body and ball:	DZR low-lead brass
	Ball:	stainless steel
	Ball control stem:	brass, chrome plated
	Ball seal seat:	PTFE
	Control stem guide:	PSU
	Seals:	EPDM

Flow meter

Materials:	Body and headwork:	DZR low-lead brass
	Bypass valve stem:	stainless steel
	Springs:	stainless steel
	Seals:	EPDM
	Flow meter float and indicator cover:	PSU

Performance:	Max. working pressure:	150 psi (10 bar)
	Max. glycol percentage:	50%
	Working temperature range:	14 - 230°F (-10-110°C)
	Flow rate range unit of measurement:	1/2 - 1 3/4 gpm 2 - 7 gpm
	Accuracy:	±10%
	Control stem angle of rotation:	90°
	Required operating wrench:	9 mm
	Connections:	1/2", 3/4", 1" union sweat, PEX crimp; 3/4" union press
	Lay length (press connection):	size 3/4" without gauge: 7 5/16" size 3/4" with gauge: 10 1/8"

NSF/ANSI 372-2011, Drinking Water System Components-Lead Content Reduction of Lead in Drinking Water Act, California Health and Safety Code 116875 S.3874, Reduction in Drinking Water Act, certified by ICC-ES, file PMG-1360.



SAFETY INSTRUCTION

This safety alert symbol will be used in this manual to draw attention to safety related instructions. When used, the safety alert symbol means **ATTENTION! BECOME ALERT! YOUR SAFETY IS INVOLVED! FAILURE TO FOLLOW THESE INSTRUCTIONS MAY RESULT IN A SAFETY HAZARD.**



WARNING: This product can expose you to chemicals including lead, which is known to the State of California to cause cancer and birth defects or other reproductive harm. For more information go to www.P65Warnings.ca.gov.



CAUTION: All work must be performed by qualified personnel trained in the proper application, installation, and maintenance of systems in accordance with all applicable codes and ordinances.



CAUTION: Over-tightening and breakage can occur with the use of Teflon® pipe joint compounds. Teflon® provides lubricity so that care must be exercised not to over-tighten joints. Failure to follow these instructions could result in property damage and /or personal injury.



WARNING: System fluids are under pressure or temperature can be hazardous. Be sure the pressure has been reduced to zero and the system temperature is below 100°F (38°C). Failure to follow these instructions could result in property damage and/or personal injury.



CAUTION: If the series 132 balancing valve is not installed, commissioned and maintained properly, according to the instructions contained in this manual, it may not operate correctly and may endanger the user.



CAUTION: Make sure that all the connecting pipework is water tight.

Caleffi shall not be liable for damages resulting from stress corrosion, misapplication or misuse of its products.



CONSIGNE DE SÉCURITÉ

Ce symbole d'avertissement servira dans ce manuel à attirer l'attention sur la sécurité concernant instructions. Lorsqu'il est utilisé, ce symbole signifie.

ATTENTION! DEVEZ-VOUS ÊTRE ALERTES ! VOTRE SÉCURITÉ EST EN JEU ! NE PAS SUIVRE CES INSTRUCTIONS PEUT PROVOQUER UN RISQUE DE SÉCURITÉ.



AVERTISSEMENT: Ce produit peut vous exposer à des produits chimiques comme le plomb, qui est connu dans l'État de Californie pour causer le cancer, dommages à la naissance ou autre. Pour plus d'informations rendez-vous www.P65Warnings.ca.gov.



ATTENTION: Tous les travaux doivent être effectués par du personnel qualifié formé à la bonne application, installation et maintenance des systèmes conformément aux codes et règlements locaux.



ATTENTION: Un serrage excessif et la rupture peut se produire avec l'utilisation de composés à joint de tuyau en Téflon®. Pouvoir lubrifiant Teflon® permet de sorte qu'il faut prendre soin de ne pas trop serrer les articulations. Le non-respect de ces instructions peut entraîner des dommages matériels et/ou des blessures.



AVERTISSEMENT: Les liquides du système sont sous pression ou de la température peuvent être dangereux. Être sûr que la pression a été réduite à zéro et la température du système est inférieure à 100°F (38°C). Le non-respect de ces instructions peut entraîner des dommages matériels et/ou des blessures. Le non-respect de ces instructions peut entraîner des dommages matériels et/ou des blessures.



ATTENTION: Si le vanne d'équilibrage, Série 132, n'est pas installé, mis en service et entretenu correctement, selon les instructions contenues dans ce manuel, il peut ne pas fonctionner correctement et peut mettre en danger l'utilisateur.



ATTENTION: S'assurer que tous les raccordements sont étanches.

Caleffi ne pourra être tenue responsable des dommages résultant de la corrosion, d'une mauvaise utilisation ou une mauvaise utilisation des produits.

Installation

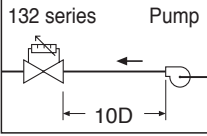
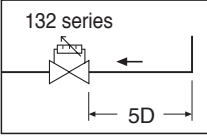

The balancing valves, with built-in flow meter, must be installed by qualified technical personnel in accordance with the instructions given in this manual and with current regulations.
Clean the pipes of any debris, rust, welding slag and any other contaminants.

As in all piping circuits it is important to pay attention to the cleanliness of the entire system.
For optimal operation, any air in the water must be removed.
In order to ensure measuring accuracy, the balancing valves with flow meter must be installed by keeping a straight section above them at least as long as five diameters, increased to at least ten diameters if the nearest device upstream is a pump.

- The valves must be installed so that:
- the direction of the flow agrees with that of the arrow on the valve body.
 - there is easy access to the flow meter valve, control stem and dial with the calibration adjustment range.
- The valves can be fitted on either vertical or horizontal pipes.

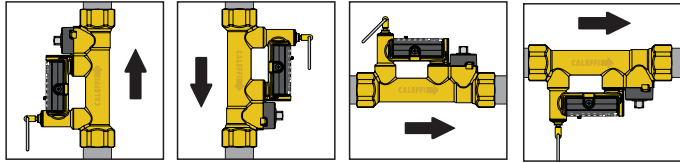

Scan to view . 132 QuickSetter

Installation Tip

Flow rate adjustment

The flow rate is adjusted by carrying out the following operations:

- A. With the aid of the indicator (1), mark the reference flow rate on which the valve is to be set.

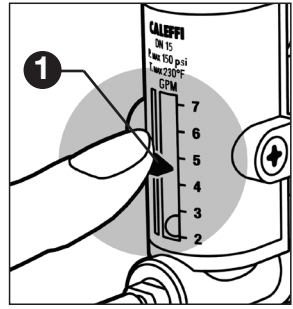

- B. Use the ring (2) to slowly open the flow meter bypass valve that shuts off the flow of medium in the flow meter (3) under normal operating conditions.

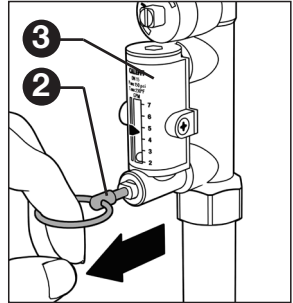

- C. Keeping the flow meter bypass valve open, apply a 9 mm wrench to the balancing valve control stem (4) to slowly adjust the flow rate, which is indicated by a metal ball (5) that runs inside a transparent cylinder (6) alongside which there is a graduated scale in GPM.

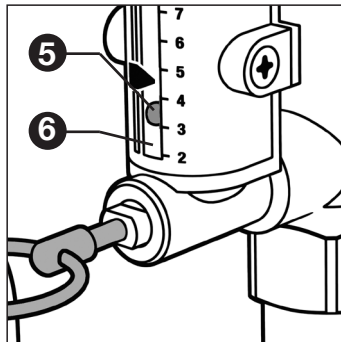
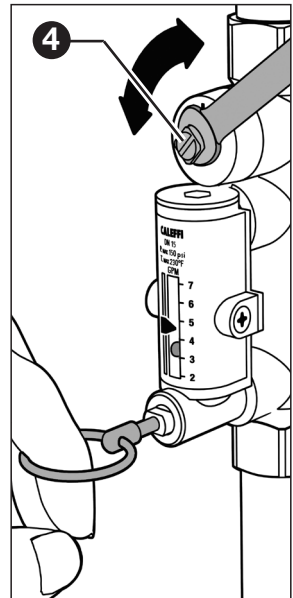

D. After completing the balancing, release the ring (2) of the flow meter bypass valve, which will automatically go back into the closed position.

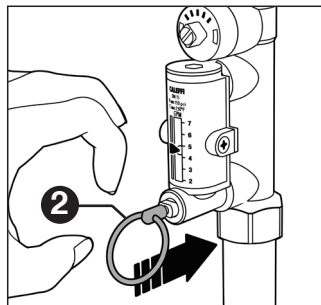

E. On completing the adjustment, the indicator (1) can be used to keep the setting in memory, in case checks need to be made over time.

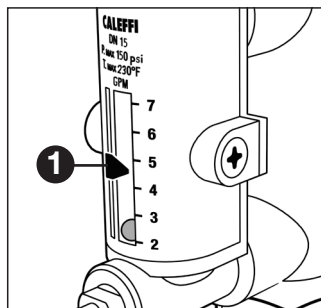

F. A replacement flow meter bypass valve stem with operating ring is available in the event it is damaged and inoperable. Order code F19346. See page 6 for replacement instructions.

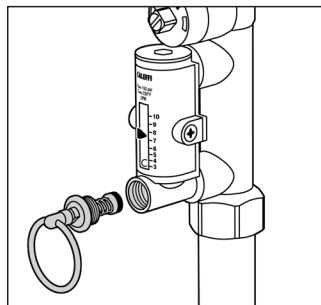

Complete closing/
opening
of valve

Balancing valve
control stem

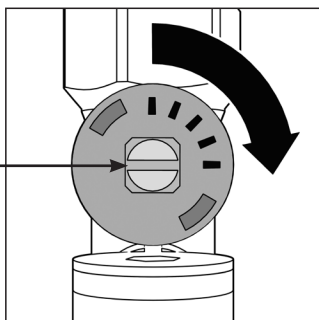

Complete closing of valve

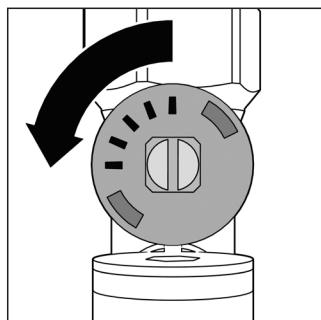

Complete opening of valve

Hydraulic characteristics at 100% open

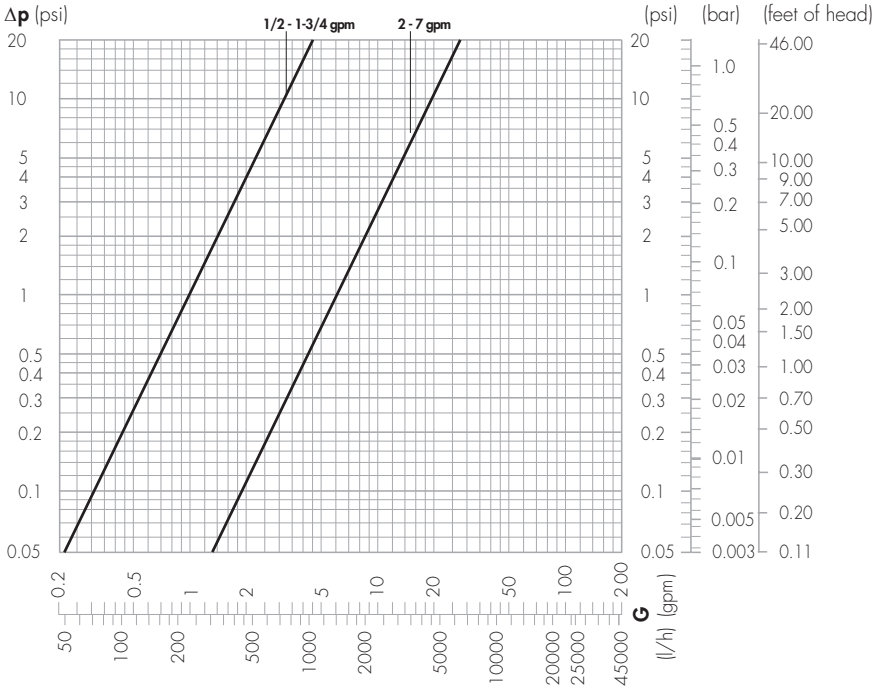

Dimensions and flow rate ranges

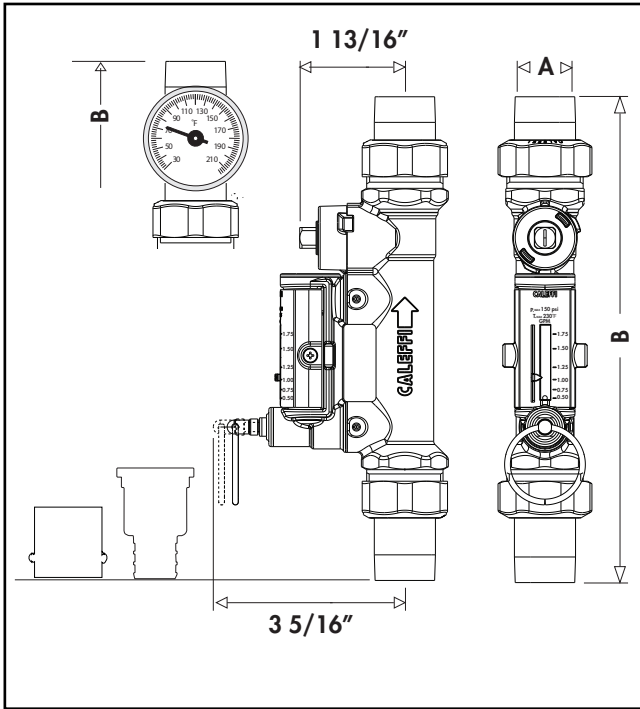

Code	A	B	Flow rate (gpm)	Fully open Cv	Wt (lb)
132434AFC	1/2" PEX crimp	9"	½ – 1¼	1.0	1.8
132439AFC	1/2" sweat	8 3/8"	½ – 1¼	1.0	2.0
132534AFC	3/4" PEX crimp	10 1/8"	½ – 1¼	1.0	2.0
132536AFC	3/4" press	9 7/8"	½ – 1¼	1.0	1.8
132539AFC	3/4" sweat	8 7/16"	½ – 1¼	1.0	1.8
132634AFC	1" PEX crimp	8 11/16"	½ – 1¼	1.0	2.2
132639AFC	1" sweat	8 9/16"	½ – 1¼	1.0	2.4
132454AFC	1/2" PEX crimp	9"	2 – 7	6.3	1.8
132459AFC	1/2" sweat	8 3/8"	2 – 7	6.3	2.0
132554AFC	3/4" PEX crimp	10 1/8"	2 – 7	6.3	2.0
132556AFC	3/4" press	9 7/8"	2 – 7	6.3	1.8
132559AFC	3/4" sweat	8 7/16"	2 – 7	6.3	1.8
132654AFC	1" PEX crimp	8 11/16"	2 – 7	6.3	2.2
132659AFC	1" sweat	8 9/16"	2 – 7	6.3	2.4
132435AFC*	1/2" PEX crimp	10 5/16"	½ – 1¼	1.0	2.2
132438AFC*	1/2" sweat	9 11/16"	½ – 1¼	1.0	2.4
132535AFC*	3/4" PEX crimp	12 5/8"	½ – 1¼	1.0	2.4
132537AFC*	3/4" press	12 1/8"	½ – 1¼	1.0	2.2
132538AFC*	3/4" sweat	9 13/16"	½ – 1¼	1.0	2.2
132635AFC*	1" PEX crimp	10 1/4"	½ – 1¼	1.0	2.6
132638AFC*	1" sweat	10 1/8"	½ – 1¼	1.0	2.6
132455AFC*	1/2" PEX crimp	10 5/16"	2 – 7	6.3	2.2
132458AFC*	1/2" sweat	9 11/16"	2 – 7	6.3	2.4
132555AFC*	3/4" PEX crimp	12 5/8"	2 – 7	6.3	2.4
132557AFC*	3/4" press	12 1/8"	2 – 7	6.3	2.2
132558AFC*	3/4" sweat	9 13/16"	2 – 7	6.3	2.2
132655AFC*	1" PEX crimp	10 1/4"	2 – 7	6.3	2.6
132658AFC*	1" sweat	10 1/8"	2 – 7	6.3	2.8

*with temperature gauge.

Application: Balanced recirculating systems

An example recirculation system is shown below:

Multiple hot and cold water risers are supplied from common hot and cold water mains. The number and type of fixtures served by each set of risers will often be different. A recirculation riser accompanies each set of hot and cold risers. A single circulator provides recirculation flow through the entire system.

This type of piping network is similar to a 2-pipe direct return distribution system for hydronic heating. Because of differences in the lengths or sizes of both the main piping and riser piping, the recirculation flow through each set of risers is likely to be different. This can lead to different temperature drops between the beginning of a given hot water riser and the end of its associated return riser. This may cause the hot water temperature arriving at a distant fixture to be insufficient for the intended usage.

This situation can be corrected by “balancing” the recirculation flow between the various sets of risers. The goal of such balancing is to establish recirculation flow rates that create equal temperature drop between the start of each hot water riser and the end of its associated return (recirculation) riser.

Balancing is enabled with the QuickSetter+™ 132X38AFC, balancing valve with flow meter, temperature gauge and check valve, near the end of each return riser. These valves are 0.25% max. lead brass, certified to 2014 lead plumbing law by IAPMO, rated for contact with potable water.

The QuickSetter+™ 132X38AFC includes a check valve so when installed as shown near the end of each recirculation riser to prevent reverse flow. Also, when the risers are vertical, as shown, the recirculation pipe should tee into the hot water riser below the final fixture take off. This allows any air bubbles that may be present in the hot water riser to leave each time hot water is drawn at the highest fixture.

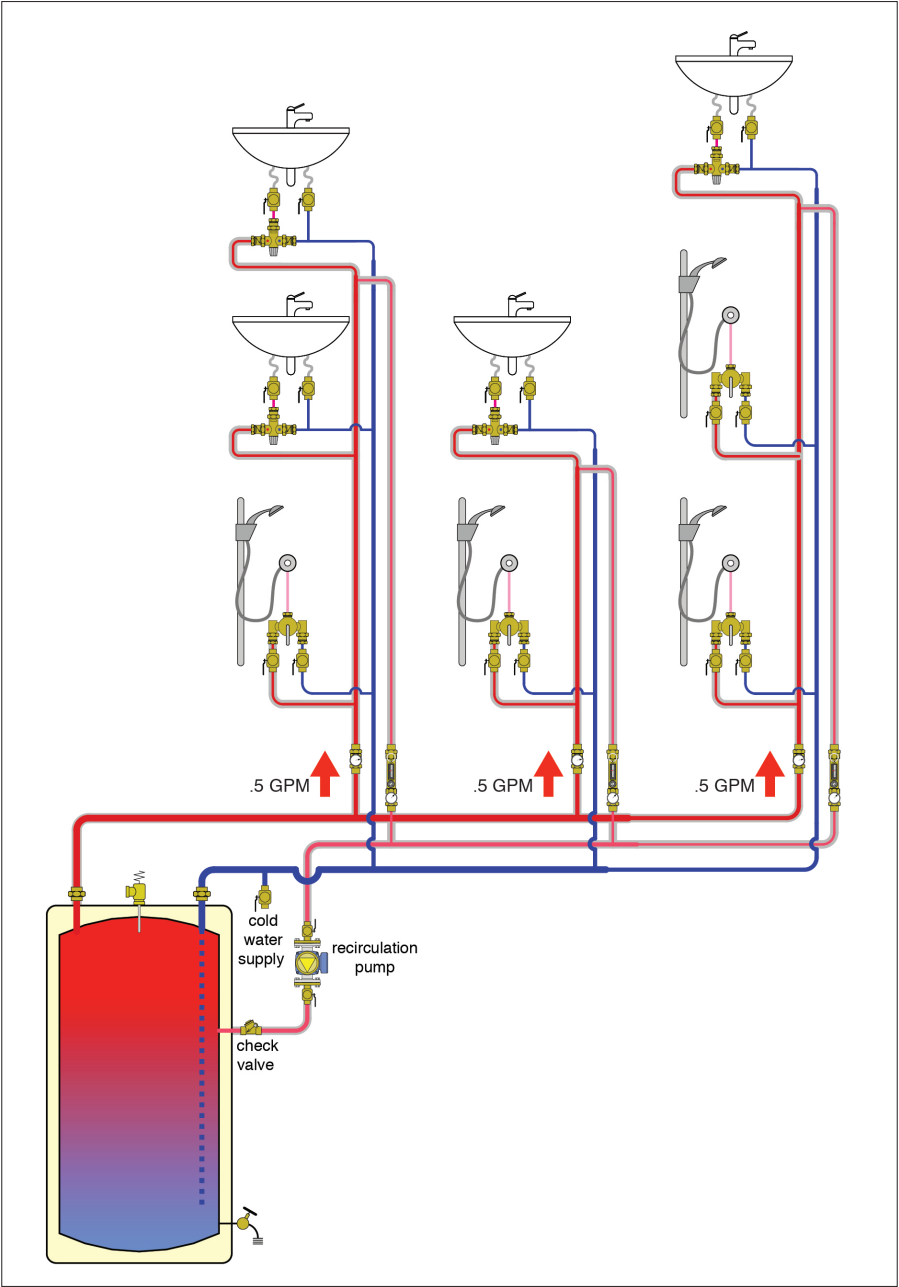

**End fitting
assembly diagram**

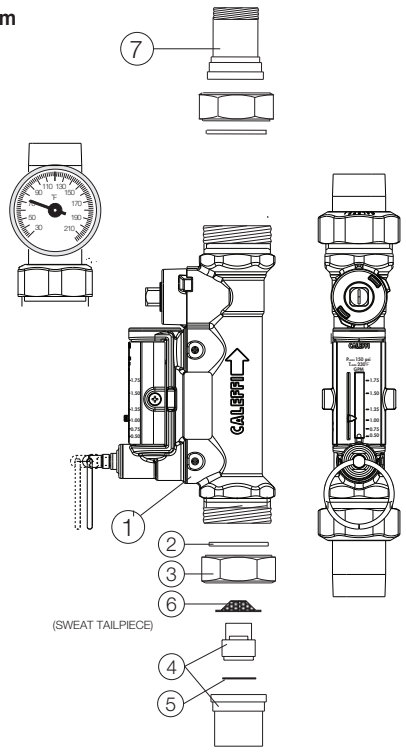

- 1 VALVE BODY
- 2 UNION WASHER, Quantity 3 per valve
- 3 UNION NUT, Quantity 3 per valve
- 4 INLET PORT MALE TAILPIECE WITH INTEGRAL CHECK VALVE, Quantity 1 per valve
- 5 CHECK VALVE O-RING
- 6 INLET PORT CONIC FILTER, Quantity 1 per valve
- 7 OUTLET PORT TAILPIECE, Quantity 1 per valve

**Procedure for
replacing bypass
valve stem with
operating ring**

1. Remove bypass valve assembly with an 8 mm wrench.
2. Install replacement bypass valve assembly, code F19346, using locktight to seal the threads.

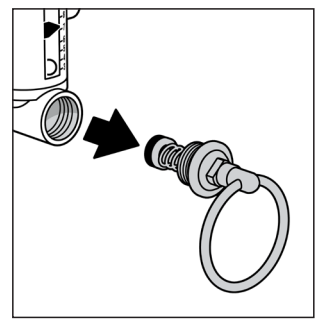
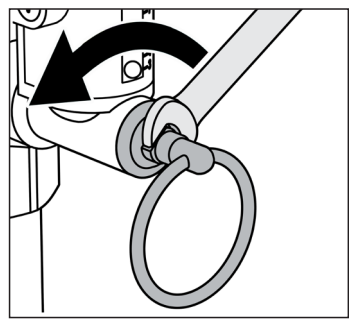

Caleffi North America, Inc.
 3883 West Milwaukee Road
 Milwaukee, WI 53208
 T: 414.238.2360 F: 414.238.2366